

GENERAL LEGEND

TO BE READ IN CONJUNCTION WITH SPECIFICATION

BH	BULKHEAD OVER
COL E	EXISTING COLUMN TO BE RETAINED AND MAKE GOOD
COL R	EXISTING COLUMN TO BE RETAINED AND MAKE GOOD. NEW PAINT FINISH WHERE SPECIFIED
COMMS	COMMUNICATIONS RACK INDICATIVE LOCATION - REFER ELEC. ENG. DWGS.
FF	CHANGE IN FLOOR FINISH - REFER TO SPEC. AND DETAIL DWGS.
FFL	FINISH FLOOR LEVEL
FE	EXISTING FIRE EXTINGUISHER
FER	RELOCATED FIRE EXTINGUISHER
FHR	EXISTING FIRE HOSE REEL
FHR R	RELOCATED FIRE HOSE REEL
GLE	EXISTING GLAZING
GL	NEW GLAZING AS SPEC.
GP	GRAPHIC PAINT FINISH TO ALL SIDES AS DETAILED UNLESS NOTED OTHERWISE
JN	BUILT IN JOINERY - REFER DETAILS
HR	HANGING RAIL AS SPEC.
OPW	OPERABLE WALL AS SPEC.
SCR	WALL-MOUNTED SCREEN - REFER ELEC. ENG. DWGS.
SNK	SINK AS SPEC.
TILE	EXISTING TACTILE INDICATORS RETAINED
TIN	NEW TACTILE INDICATORS AS SPEC.

NOTES

MAKE GOOD EXISTING WALL FINISHES, SKIRTING AND CEILING WHERE SERVICES (E.G. GPDS OR SWITCHES) HAVE BEEN RELOCATED. REMOVE ANY REDUNDANT SWITCHPLATES AND ALSO MAKE GOOD IN THESE AREAS. REPLACE SKIRTING WHERE DAMAGED.

REFER TO STRUCTURAL, FIRE, AND SERVICES ENG. DOCUMENTATION

SCOPE OF WORKS TO BE DEMOLISHED INDICATED IN RED

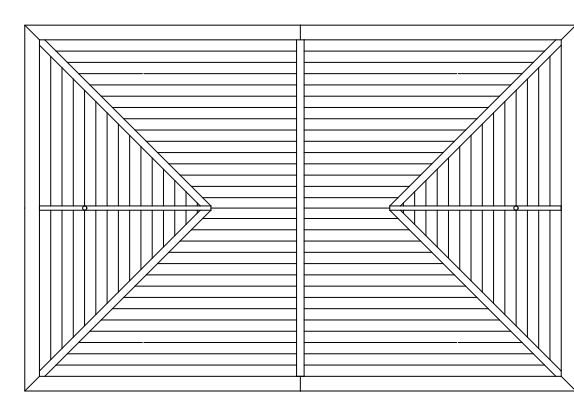

ROOF PLAN
EXISTING

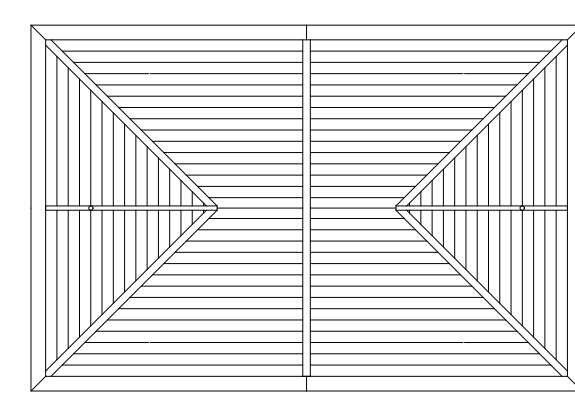

ROOF PLAN
PROPOSED

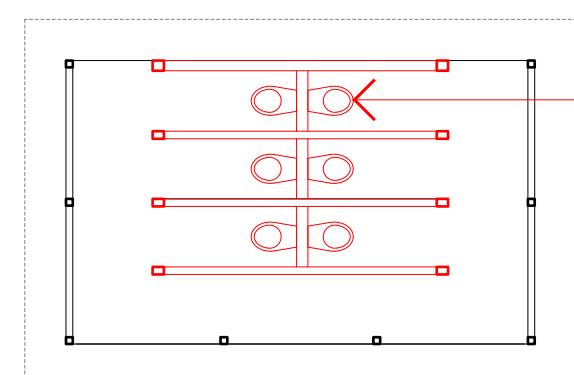

DEMOLISH EX. WATERCLOSESTS,
PARTITIONS WALLS, ASSOCIATED
PLUMBING FIXTURES, MAKE GOOD

PLAN
EXISTING

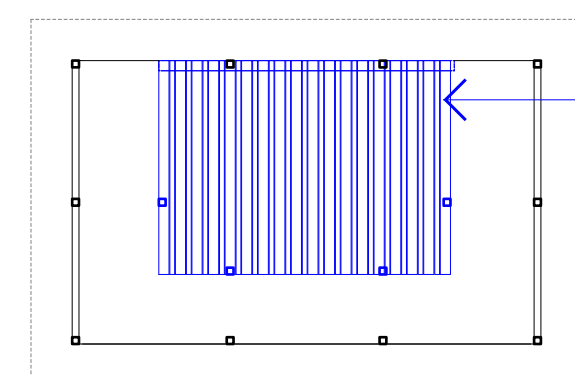

NEW SEATING TO MATCH EXISTING
TOILET FOOTPRINT

PLAN
PROPOSED

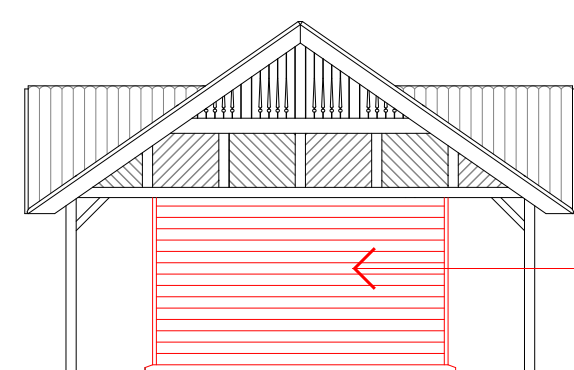

DEMOLISH EX. EXTERNAL SCREENS
+ ASSOCIATED STRUCUTRE

WEST ELEVATION
EXISTING

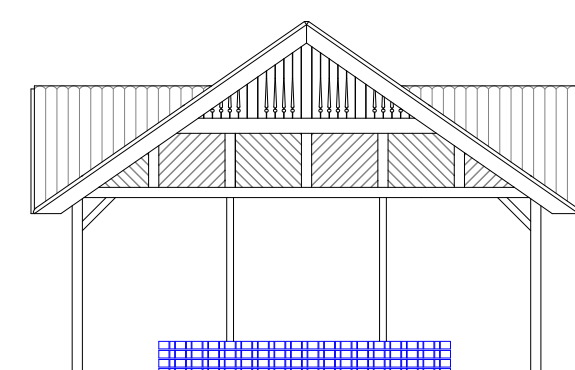

WEST ELEVATION
PROPOSED

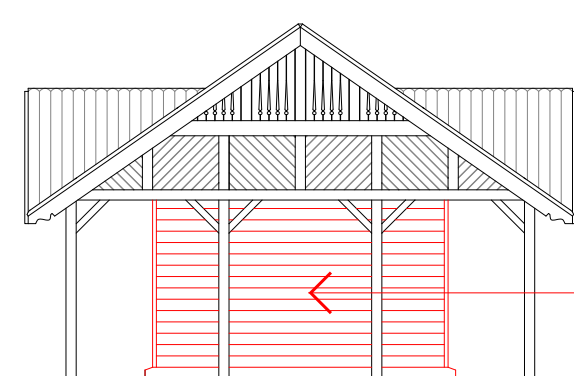

DEMOLISH EX. EXTERNAL SCREENS
+ ASSOCIATED STRUCUTRE

EAST ELEVATION
EXISTING

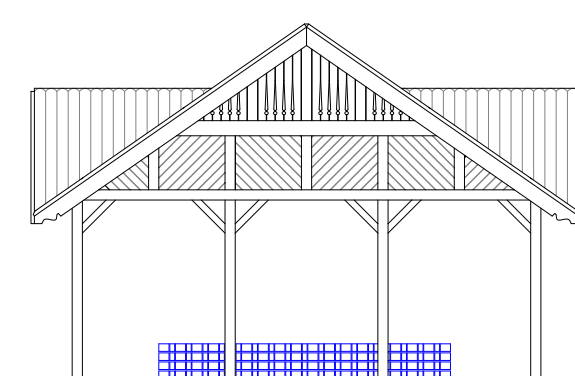

EAST ELEVATION
PROPOSED

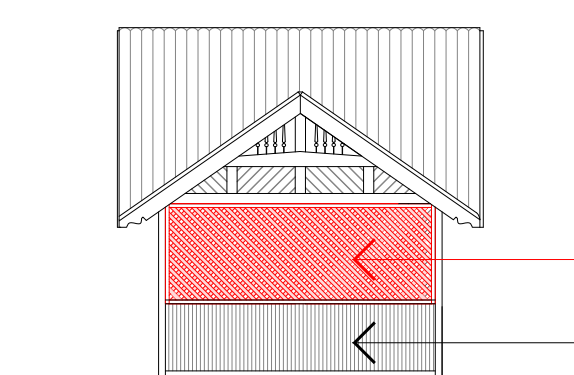

DEMOLISH EX. EXTERNAL SCREENS
RETAIN EX. LOW SCREENS ON TWO
SIDES

NORTH ELEVATION
EXISTING

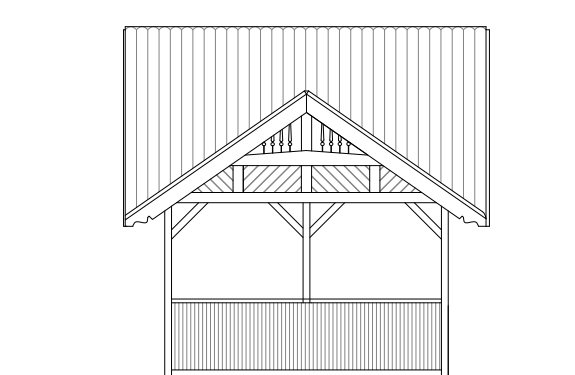

NORTH ELEVATION
PROPOSED

Revision	Date	Issue
A	22.11.24	ISSUED FOR COORDINATION

NOTES

THIS DRAWING IS AN UNCONTROLLED COPY UNLESS STAMPED OTHERWISE. CONTRACTOR SHALL VERIFY JOB DIMENSIONS BEFORE COMMENCING ANY WORK. WHERE SHOP DRAWINGS ARE TO BE SUBMITTED MANUFACTURE SHALL NOT COMMENCE BEFORE RETURN OF UNAMENDED SHOP DRAWINGS SIGNED BY RESPONSIBLE CONSULTANT. DO NOT SCALE CRITICAL DIMENSIONS. THE DRAWINGS SHOULD BE READ IN CONJUNCTION WITH ALL RELEVANT CONTRACT, SPECIFICATIONS AND DRAWINGS. THIS DRAWING & DESIGN IS COPYRIGHT BY ARCHITECTURE ASSOCIATES. BUILDER TO CONFIRM ALL DIMENSIONS ON SITE.

DO NOT SCALE OFF THE DRAWING.
REFER ANY DISCREPANCIES TO THE ARCHITECT.
[THIS DRAWING TO BE PREVIEWED IN COLOUR](#)

Architecture Associates

Architect
Architecture Associates Pty Ltd
T: 03 8412 9751
E: office@architectureassociates.net
W: www.architectureassociates.net

Client
Hume City Council
1079 Pascoe Vale Road Broadmeadows Vic 3047
PO Box 119 Dallas Vic 3047

Project No.	2408 SCACP
Project Title	SCACP - SUNBURY COMMUNITY ARTS & CULTURAL PRECINCT
Drawing	BUILDING 24 PLANS & SECTIONS
Scale	1:100 @ B1
Status	FOR INFORMATION
Date	22.11.2024
Drawing No.	A160